

DEEP FREEZER 25L

SC-DF25

Instruction Manual

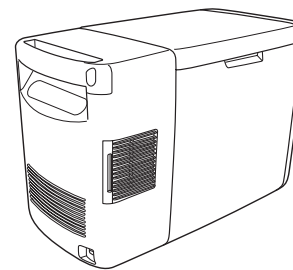

- Read this manual carefully before using this product. Improper handling may result in an accident.
- Be sure to save this instruction manual.

● **Table of Contents**

Safety Precautions	1, 2
Features	3, 4
Using the Product	5, 6
Storing Food Items	7
Maintenance	8
Extended Disuse	9
Troubleshooting	9
After Sales Service	10
Specifications	10

Safety Precautions Follow carefully

To prevent personal injury, injury to others, or damage to property, read these safety precautions carefully before use and use this product accordingly.

Warning

 Do not immerse in water or pour water on the unit. Also, do not expose to damp or wet environments.

Use in water prohibited

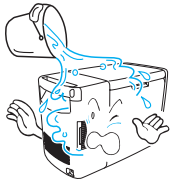

Risk of short circuit or electric shock.

 Do not let children use the product alone. Keep infants away.

Prohibited

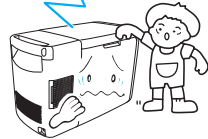

Risk of burns, electric shock or injury.

 Do not store flammable items such as gasoline, thinner and spray.

Prohibited



Danger of explosion from gasoline, thinner and spray.

 When setting the temperature to under the freezing point, do not store items such as glass bottles or cans that break or burst easily.

Prohibited



Contents may freeze and break the container.

 This unit must not be disassembled, repaired or modified by anyone except a repair technician.

Disassembly prohibited

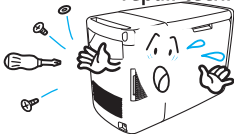

Risk of combustion or malfunction causing injury.

 When opening or closing the lid, do not place your hand at the edge of the container.

Warning

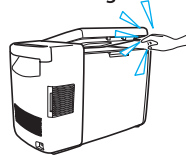

Hand may get caught, causing injury.

 Do not place heavy items on the lid.

Prohibited



Heavy item may fall, causing injury.

 Do not touch the inside of the Coolbox with wet hands.

Prohibited

Risk of frostbite.

 Unit becomes heavy after storing items inside.

Caution Use caution when transporting.

Caution

 Do not place ice or water directly inside the Coolbox.

Prohibited

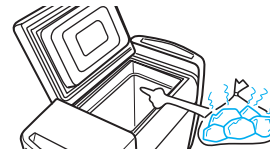

May cause shock, malfunction

 Do not remove frost or ice on the inside of the Coolbox using a knife, screwdriver, etc.

Prohibited

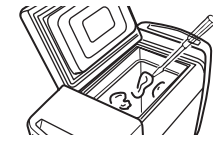

The inner box is a condenser, which may malfunction if scratched.

 Do not block the air intake area or air discharge vent.

Prohibited

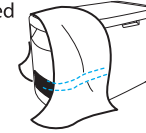

May cause malfunction.

 Do not insert foreign materials in the intake area or discharge port.

Prohibited

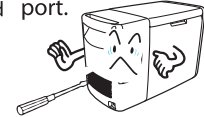

 Do not place objects or weight on the unit. Product may be damaged.

Prohibited

 Do not cut, damage, modify, forcedly bend, pull, twist or knot the power cable. Also, placing heavy objects on the cable or forcing it into small spaces will damage the cable, which may result in fire or electric shock.

Prohibited

 Do not use if the power cable, DC plug or power plug are damaged, or the DC power socket is loose.

Prohibited

May cause electric shock, short circuit or combustion.

 Remove the power plug before turning off the engine. The power does not turn off after switching off the engine in some cars. If the power plug is left connected, the battery may become depleted.

Warning

 Do not use in the car trunk without adequate ventilation. The temperature may rise, causing damage.

Prohibited

 When removing the power plug, be sure to hold the end of the plug rather than pulling on the power cable. There is danger of electric shock or short circuit causing fire.

Warning

 Avoid strong physical shock. This may cause damage to the electronic components inside.

Prohibited

 Use the handles when carrying the product. Holding the product using other parts may cause you to drop it, resulting in injury.

Warning

Switches and Operations

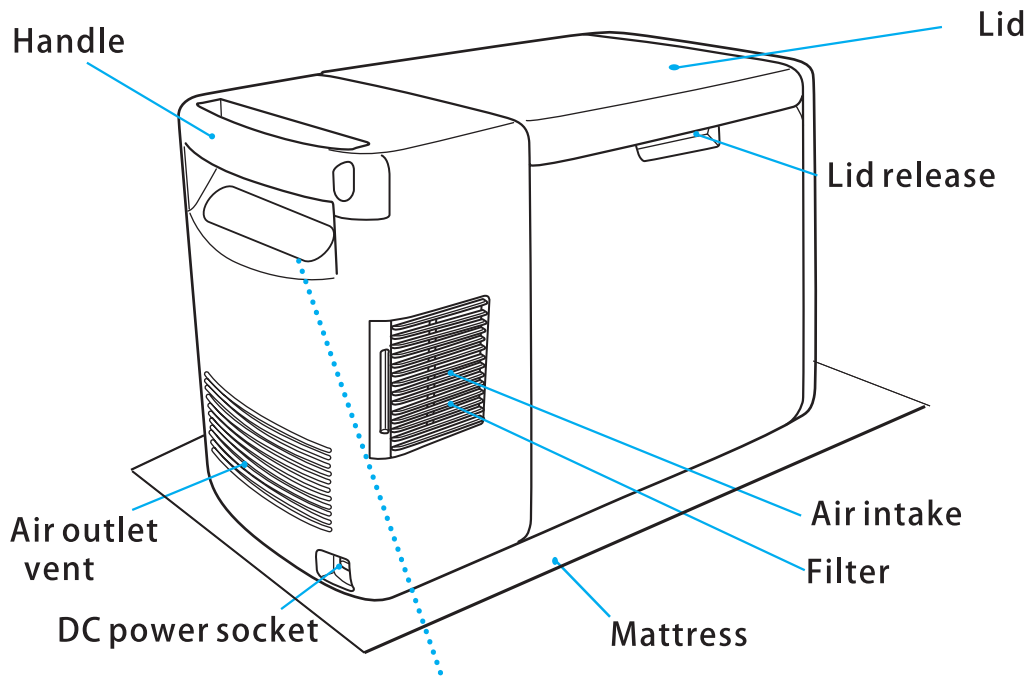

Warning

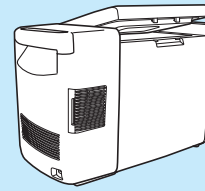

Opening/Closing the lid
The lid is equipped with a safety mechanism that slowly closes it when it has been opened or closed. If the lid is half open, the mechanism will not operate properly, and the lid may shut forcibly under its own weight. therefore, open and close the lid gently to avoid getting your hand caught.

Accessories

DC Power Plug

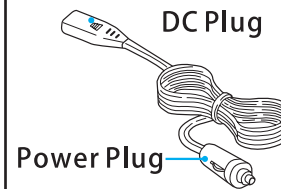

Mattress

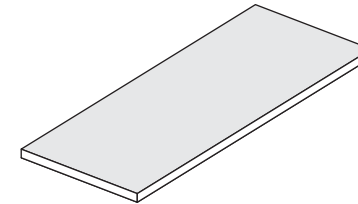

AC Adaptor

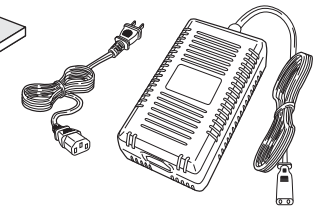

Power indicator

Temperature SET indicator
While the light is flashing, temp setup is possible by pushing SET button once. Push once again after changing setting temperature with a temperature-control button.

Status indicator:
When the temperature in the Coolbox reaches below the set temperature, the flashing lights change to steady state.

Low-battery indicator:
When the input voltage from battery became low, the Low-battery LED flashes.

Error indicator:
When the temperature of the unit's cooling system rises, this Error indicator LED flashes.

Power button
Press the power button once to turn the power on or off.

Temperature control button (UP/DOWN by 1°C)

Temperature pre-set button for -40°C, -20°C and 4°C.

DC Power Plug

Power Plug

Mattress

AC Adaptor

TWINBIRD SC-DF25

Power

Set

Status

Bat. Low

Error

-40

-20

4

DEEP FREEZER

Using the Product

1. Set the unit up on a flat surface

⚠ Caution

Condensation may form on the outside of the unit depending on the environment. Please put a matress under the unit. (grey side facing up)
Set up the unit in a location that does not interfere with driving.
Do not use the unit on a surface tilted more than 12 degree for it may result in malfunction.

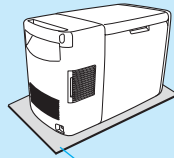

2. Connect a power

<At AC 100V>

1. Insert the DC plug of AC adaptor into the DC power socket.
DC plug has a (+) and (-).
2. Insert the AC plug of AC adaptor to the

⚠ Warning

- Use only the included AC/DC adaptor.
- Please do not cover the AC/DC adaptor. The AC/DC adaptor generates heats and could cause a fire.

< At DC12V >

1. Start the engine.
2. Insert the DC plug into the DC power cable socket of the main unit.
3. Insetr the DC cable power plug into the cigarette lighter socket.

⚠ Warning

- Insert the power plug as far as it will go.
- Keep the cigarette lighter socket clean. Poor contact will cause the contact area of the power plug to become hot, and the operation of the product to stop or become unstable, resulting in reduced performance.
- Do not use a cigarette lighter socket splitter or extension cable. The voltage will drop and the unit may stop working.

3. Press the power button.

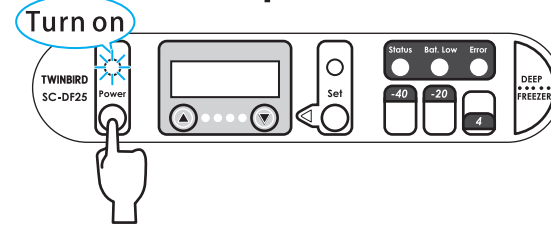

PowerLamp turn on and operation start.

4. Push the SET button to set the setting temperature

Press the SET button to enter control mode. The desired temperature will be displayed..

Press Set button once again after temperature selection, Acted temperature will be displayed.

⚠ Caution

- After turning the power off, the temperature setting will remain in memory for some time. If the power remain off for several hours, the the setting temperature will return to default.
- Condensation will form on the product during operation. Quickly wipe any moisture that forms on the main unit.

⚠ Caution

The DC power cable has a (+) and (-).
Align the protrusion of the DC socket with the indentation in the DC power cable and insert.
Wrong connect will cause damage.

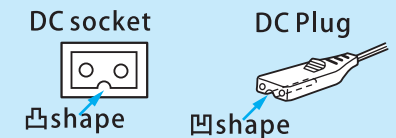

Can not be used in 24V vehicles(Truck, Bus, etc)
12V only.
Attaching it to a 24V source will cause damage.

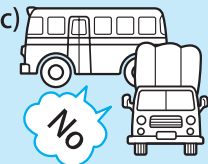

Be careful of the current capacity

When using this product together with other electrical car products, be careful of the current capacity.

Be sure to connect to the DC plug when powering the unit via the car power source.

Too many leads in a single socket may cause fire due to a shot circuit, overheating by exceeding the battery`s capacity in malfunction or damage.



Storing Food Items

Do not store for long periods.
Use items in the order stored.

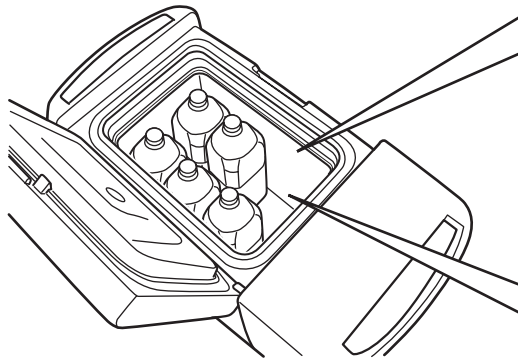

Inside the Coolbox

- To prevent spoilage from dipping water, put water-sensitive items in a plastic bag, etc., before storing.

Defrosting

- Defrost the Coolbox regularly. Frost will form on the inside of the Coolbox. To defrost, turn off the power and wipe the inside of the Coolbox with a soft cloth to remove moisture after the frost has thawed.

When there are few items in the Coolbox

- Lay bottles on their side to prevent them from falling and breaking.

Leave adequate space



Overloading interferes with the flow of cold air.

Clean food products

Wipe off moisture or dirt before storing items. As for the food such as vegetables and fruits, which will be touched directly with mouth, put it in a plastic bag etc., before storing

It is best to store items that have been pre-refrigerated.

Do not store items that are 60°C(140F) or over.



Items with a different temperature from that of the Coolbox will take time to cool.

Seal items in airtight containers, plastic bags or plastic wrap.

Sealing items prevents odors from spreading and food from drying out.

Keep lids on bottles or containers tightly closed.

Maintenance

Press the power button to turn off the unit, and carry out the following maintenance after unplugging the power cable.

Main unit

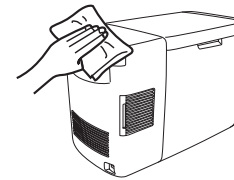

Immerse a soft cloth into mild dish detergent diluted with water and wipe the main unit after wringing the cloth.

Caution

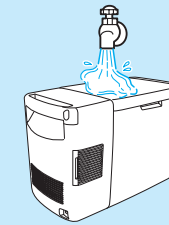

Never immerse the unit in water.

Never wipe the unit using thinner, benzene or spray cleaners. Do not rub the unit with a scrubbing brush, cleanser, etc.

Air intake area

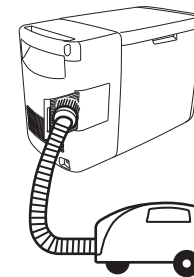

Clean the air intake area with a vacuum cleaner at least once a month.

- If the air intake filter is dirty, product performance will be hampered.
- Remove stubborn dirt by rubbing gently with a commercially-available brush.

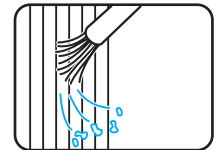

Accessing the filter

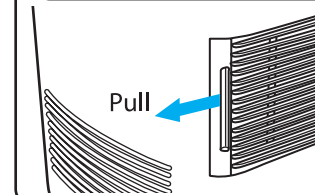

Caution

The filter cannot be completely removed. Clean after pulling open for access.

Caution

After cleaning the filter, return it to its original position to avoid malfunction.

Handling condensation

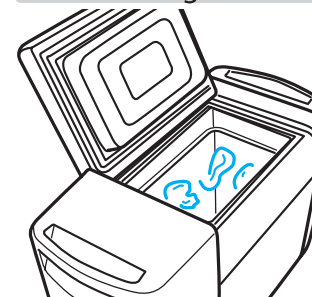

Condensation will form on the product during operation. Quickly wipe any moisture that forms on the main unit, or drips out of the Coolbox.

- Put water-sensitive foods in containers or plastic bags before refrigeration.
- Condensation is a natural phenomenon, and is not a sign of malfunction.

Extended Disuse

1. Switch the unit off using power button and remove the power plug.
2. Remove any items being stored in the Coolbox. Clean the inside of the Coolbox and wipe off any moisture.
3. Open the lid occasionally to refresh the air in the Coolbox.
For improved effectiveness, place a commercially-available deodorizer in the Coolbox.

Troubleshooting Please check the following points before requesting repairs.

Problem	Possible Cause	Solution
Unit does not turn on	Power button has not been pressed continuously for 1 second.	Push the button until you hear a high-pitched tone (approximately 1 second).
	Power plug is not properly inserted in the cigarette lighter socket.	Push the plug as far as it will go.
	There are ashes or dust in the cigarette lighter socket.	Clean the cigarette lighter socket.
	A car fuse has blown.	Replace the fuse.
	The DC power cable fuse has blown.	Replaced the DC power cable fuse.
	The low-battery light is flashing.	Check the battery condition.
Unit does not cool sufficiently	There are too many items in the Coolbox, obstructing air circulation.	Remove some of the items in the refrigerator.
	The lid is not completely closed.	Close the lid properly and lock it.
	The unit is exposed to direct sunlight or there is a gas burner or stove nearby.	Change the location of the unit.
	The vents are covered.	Remove any items covering the vents.
	The lid is being opened and closed too often.	Minimize opening and closing of the lid.
	The filter is clogged.	Carry out filter maintenance.

Error Code Table

Err 0	FPSC is not connected
Err 1	The temperature in the Coolbox is too high
Err 2	The temperature in the Coolbox is too low
Err 3	The temperature on the surface of the FPSC is too high
Err 4	The temperature on the surface of the FPSC is too low
Err 5	Input voltage is too low (9.5V or less)
Err 6	Input voltage is too high(16.5V or more)

Specifications

Operating voltage	DC12V
Power consumption	48W (4A)
Setting Temperature	-40°C~10°C (Ambient 25°C)
Operating Temp. range	0°C~35°C
Usable capacity	25L
Dimension	W695×D350×H460mm
Weight (Approx.)	15kg
Cable	DC Power Cable···3m
Accessories	DC power cable···1、AC adaptor···1、mattress···1