



ULUF P820

HIGHLY RELIABLE ULTRA LOW TEMP. FREEZER WITH DOUBLE SECURITY

ULUF P820 freezer comes with independent TRUE DUAL™ technology that offers the highest level of security for your valuable samples.



TRUE DUAL™
TECHNOLOGY



VACUUM
INSULATED
PANELS



NOISE
REDUCTION
TECHNOLOGY



AIRFLOW
CONTROL



FILTERLESS
CONSTRUCTION



DIRECT
COOLING



ONEGRIP™
HANDLE

WORKING ENVIRONMENT

The Integraline helps provide a pleasant work environment where they are installed by placing the compressor and other heat and noise generating components on top of the unit, rather than the bottom. By placing the components on top of the freezer, there is never a compartment that you will have difficulties overlooking or using fully. Ensuring an ergonomically correct unit, which is easy and pleasant to use on a day-to-day basis.

We are also able to reduce the noise level to only 49 dBA with our *Noise Reduction Technology*, ensuring a pleasant work environment.

RELIABLE AND ENERGY EFFICIENT

The Integraline is developed with our advanced technologies and with the best components to secure the best performance. Besides of the regular polyurethane foam the Integraline has a layer of vacuum insulated panels (VIP), that provides an even better insulating effect, this helps provide a stable cooling performance while also lowering the energy consumption.

Our filter less construction makes cleaning unnecessary. With our compressors located on top, the dust intake is minimal - eliminating the need for filters entirely, saving you maintenance time and cost.

ULTIMATE SAMPLE PROTECTION

Do not risk the safety of your samples due to the potential of a breakdown of your freezer. With *TRUE DUAL™ technology* you will avoid all the problems caused by an unexpected breakdown of the compressors.

In the event of any failure on one of the cooling systems, the other system will still maintain the temperature of -70°C meaning your valuable samples at all times are stored with best possible security. Don't ignore the huge risk of losing many years of valuable research because of poor laboratory equipment.

MAIN DIMENSION FOR ULUF P820

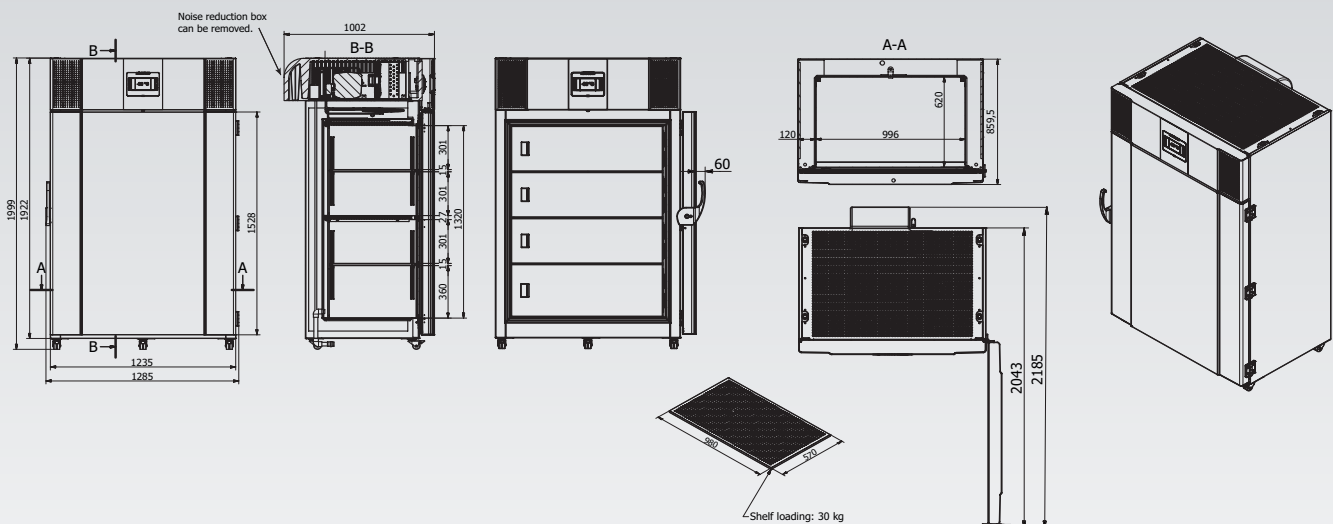



The sublids are all easy detachable to ease and speed up the cleaning process.



The new developed V700 controller comes as standard on the new Integraline with self diagnostics test and ECO-mode.



The shelves in the new Integraline are perforated and easy adjustable in order to offer best flexibility for your storage needs.

OPTIONAL ACCESSORIES

- CO2 backup
- Chart recorder
- SVS voltage stabilizer
- GSM alarm module
- Racks & boxes
- Cryo gloves
- Modbus adapter

MAIN SPECIFICATIONS

Item code	DAI 1815
Temperature range (°C)	-40 / -90
Max. ambient temperature (°C)	25
Capacity (L)	815
Exterior dimensions WxDxH (mm)	1285x859,5/1002*x1999
Interior dimensions WxDxH (mm)	996x620x1320
Weight (KG)	273
Insulation (mm)	120
Cooling technology	dual system / static
Controller model / probe type	V700 / PT100

POWER

Power supply (V)	230
Frequency (Hz)	50/60
Power consumption (kWh/24H)	18,7
AMP (A)	9,6
Power (Watt)	1354
Horse power (HP)	2 x 3/4

ALARM FUNCTIONS

Alarm display as text - not codes	yes
Visual / acoustic alarm	yes / yes
Power failure alarm	yes
Adjustable high / low temperature alarm	yes / yes
Open door alarm	yes
Probe failure alarm	yes
Low battery alarm	yes
Compressor failure alarm	yes
Battery backup for alarms (approx. hrs.)	72

DATA LOGGING & EXTERNAL CONNECTION

Voltage free contact for remote alarm (e.g. GSM alarm module)	yes
Electronic data logger	yes
RS 485 port	optional
USB port for software update & data download	yes
Temperature chart recorder	optional

DISPLAY FEATURES

Display type	7" touch screen
Number of optional reference probes	1
Password protection for turning unit on / off	yes
Temperature graph on display	yes

OTHER FEATURES

Automatic defrost	no
Antifreeze function	no
Vacuum release port	yes
Access port for external probe etc. (int. diameter mm)	12
Light	yes
Lock with key	yes
Castors (total pcs) / castors with brake (pcs)	5 / 2
Fixed feet (pcs) / levelling feet (pcs)	no
Sub lids / inner doors (pcs)	4
Reversible door(s)	no
Fixed shelves (pcs) / adjustable shelves (pcs)	1 / 2
Max. no. of shelves (pcs) / recommended max. no. of shelves (pcs)	5 / 5
Max. load per shelf (kg)	30
Total capacity of 50 mm boxes 9x9 dividers (pcs)	588
Total capacity of 75 mm boxes 9x9 dividers (pcs)	364
Total capacity of 96 mm boxes 9x9 dividers (pcs)	252

REFRIGERATION & CABINET

Number of compressors	2
Refrigerant	EP88
Interior cabinet material	stainless steel
Exterior cabinet material	electrogalvanized steel
Colour (exterior cabinet)	white
Foam type	polyurethane
VIP vacuum insulated panels	yes

SHIPPING

Shipping weight (KG)	423
Shipping dimensions WxDxH (cm)	141x127x225
Shipping volume (m ³)	4,03

* Depth of 1002mm includes detachable airflow management and noise reduction system